

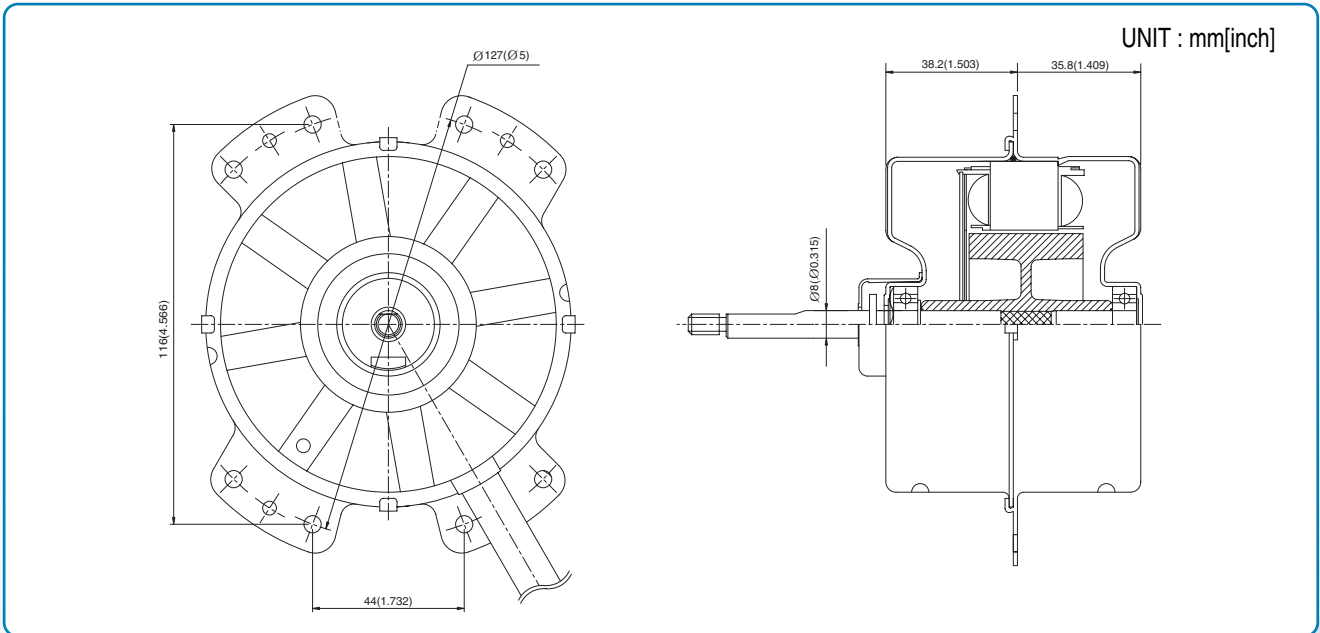

DIMENSION



CHARACTERISTIC

Type	Voltage (V)	Frequency (Hz)	Load				Ins. Class	P.C.B Of Drive	X	
			Torque		Speed	Input				Output
			(kg.cm)	(N.m)	(Rpm)	(Wi)				(Wo)
DL-95820	DC 310	-	5.5	0.54	1080	82	61	E	Internal	-