

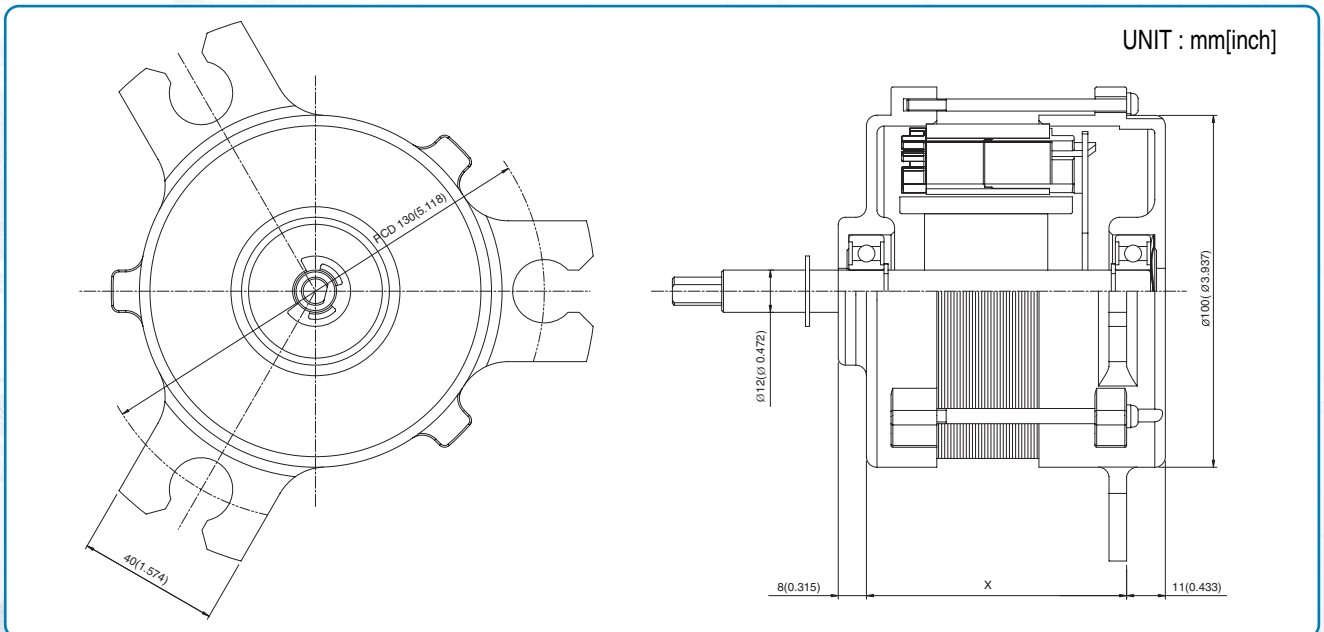

DIMENSION



CHARACTERISTIC

| Type | Voltage (V) | Frequency (Hz) | Load | | | | | Ins. Class | P.C.B Of Drive | X |
|----------|----------------|-------------------|---------|-------|----------------|---------------|----------------|---------------|----------------------|-------------|
| | | | Torque | | Speed (Rpm) | Input (Wi) | Output (Wo) | | | |
| | | | (kg.cm) | (N.m) | | | | | | |
| DL-95820 | DC 310 | - | 5.5 | 0.54 | 1080 | 82 | 61 | E | Internal | 58.4(2.299) |
| DL-95835 | DC 310 | - | 11 | 1.08 | 700 | 110 | 79 | E | Internal | 73.9(2.909) |
| DL-95835 | DC 310 | - | 14 | 1.37 | 650 | 145 | 92 | E | Internal | 73.9(2.909) |